

BLACK OR DARK OLIVE GREEN

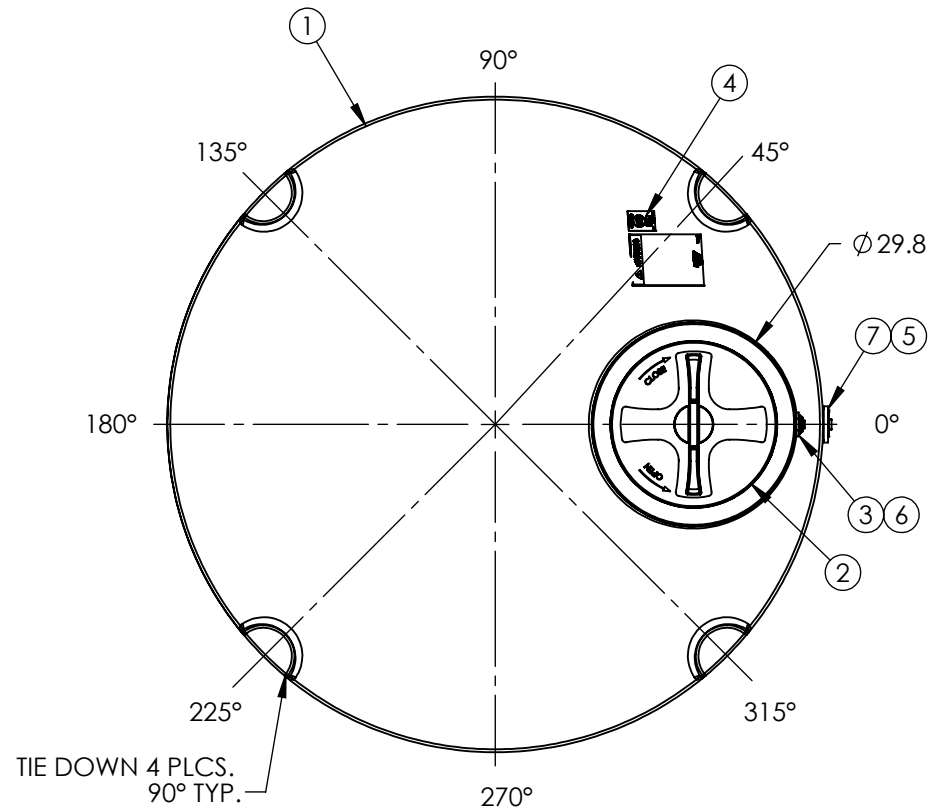
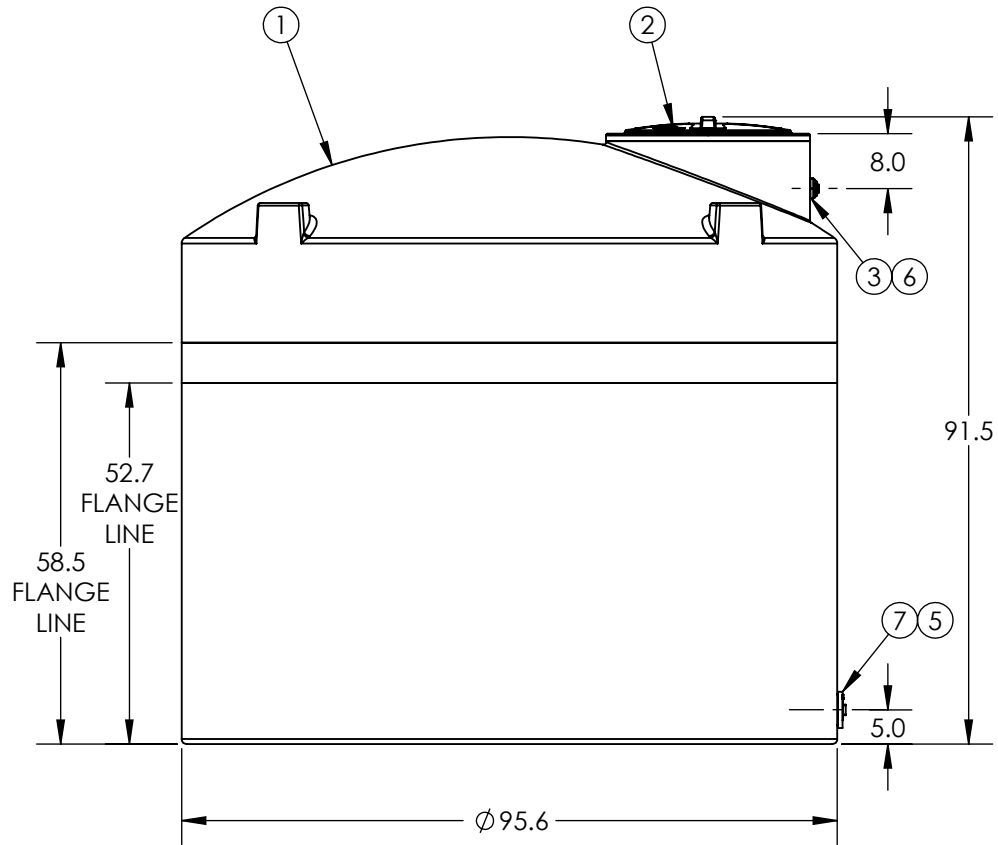

7	1	63683	FTG 2IN HD BH PP/EPDM
6	1	64149	1-1/2" NPT PLUG
5	1	60021	2" NPT PLUG
4	1	99700231	DECAL NSF MARK - WATER TKS
3	1	63931	FTG PP 1-1/2IN ECO-BH EPDM TXT
2	1	34700352	ASM MANWAY PE 24IN VENTED
1	1	5090200W__02	ASM TK 2600VDT X 96 WATER NH/NOMW

***ALL EXTERNAL PIPING MUST BE INDEPENDENTLY SUPPORTED.**
***ONLY BASE FITTINGS TO BE LEFT INSTALLED AT TIME OF SHIPMENT PER SII PROCEDURE.**
***TANKS ORDERED WITH FOAM INSULATION WILL HAVE AN INCREASED DIAMETER OF 4-6 INCHES.**
***Consult Snyder's Guidelines for Use and Installation prior to delivery.**
 Available on-line at <http://www.snyderindustriestanks.com/Technical>

ALL DIMENSIONS ARE IN INCHES, NOMINAL, & SUBJECT TO CHANGE WITHOUT NOTICE.
ALL DIMENSIONS ON ROTATIONAL MOLDED PARTS ARE SUBJECT TO A ± 3% TOLERANCE.

ITEM NO.	QTY.	PART NUMBER	DESCRIPTION
DO NOT SCALE		DRAWN BY	REVISION
STATUS: Released		BH	C
© SNYDER INDUSTRIES, LLC, 2020		SNYDER INDUSTRIES	TITLE: ASM TK 2600VDT X 96 WATER
ALL DIMENSIONS, DESIGNS, AND INFORMATION ON THIS PRINT MUST BE CONSIDERED PROPRIETARY TO SNYDER INDUSTRIES, LLC, AND MAY NOT BE USED, COPIED, OR DISTRIBUTED WITHOUT WRITTEN PERMISSION OF AN OFFICER (OR HIS AGENT) OF THE FIRM.		(402) 467-5221 www.snyderinet.com	SHEET 1 OF 1
PART NO. 5090200W__03		ENG. ID. D006336	